



FLUIDIZED-BED SEPARATORS

V-135D & V-135E



PRODUCT DESCRIPTION

The V-135 models are the smallest Sutton-Steele separators. Capacity ranges from 150 to 500 pounds per hour of any dry, granular, free-flowing bulk material - depending upon the particle size, particle shape and bulk density of the mixture. Adjustable cutting fingers allow separation into as many as four different fractions.

Indexed controls for air flow, vibration frequency and deck lopes are readily accessible and easily adjustable for any type of material. Interchangeable decks are available to meet virtually any application requirements. Deck frames are wood or, for sanitary applications, aluminum. Plastic cartons for sample collection are supplied with each unit.

V-135 separators are ready to operate when shipped. Dynamically balanced, they require only a stable, level surface for mounting.

Applications include cleaning or grading of nuts, grass seeds, tree seeds, cereal grains, flower and vegetable seeds, beans, peas, corn and other dry food products.

The V-135 can also be used for separating metallic prills from crushed slag; contamination from granulated plastics; copper and aluminum from granulated scrap insulated wire; hulls from oilseeds (soybean, sunflower, safflower, etc.); sticks and stems from leafy spices; shell from nut meats, and mica flakes from gangue.

ELECTRICAL CHARACTERISTICS

V-135E*	V-135D
220 volt AC	115 volt AC
50 or 60 cycle	50 or 60 cycle
single phase, 10 amp.	single phase, 20 amp.

*The V-135E is supplied with a transformer which includes an auxiliary 110 volt outlet for the optional feed hopper and variable-rate feeder. Other transformers can be substituted to meet other electrical characteristics.

DRY SEPARATION BY FLUIDIZATION

Like the larger Sutton-Steele separators, the V-135 models use the principle of dry separation by fluidization to grade or separate heterogeneous mixtures into two or more component fractions on the basis of one of three particle characteristics - size, shape or bulk density. As long as two of the three particle characteristics are controlled within certain limits, the fluidized-bed separator (also known as the Gravity Separator or Air Table) is unmatched in its ability to separate a complex mixture into several fractions across the range of the differentiating characteristic (from light to heavy, fine to coarse, or platy to granular shape.)

The separation or gradation is made by passing the product over a vibrating, flat, porous deck sloped in two directions. As the mixture is fed to the narrow side of the trapezoidal deck, low-

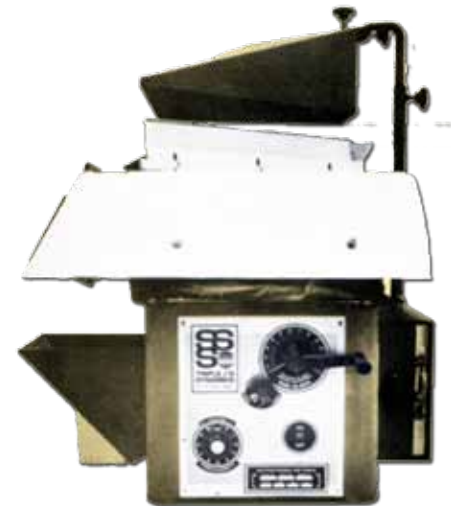
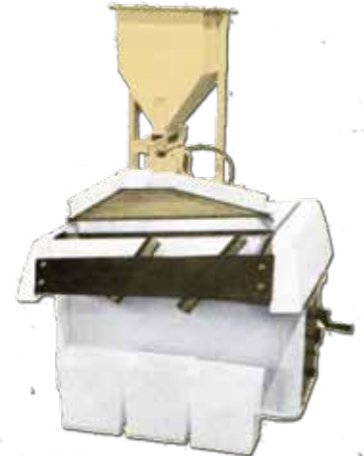



FLUIDIZED-BED SEPARATORS

V-135D & V-135E

pressure air fluidizes and stratifies the material according to the terminal velocity of each particle.

“Heavy” particles sink to the bottom of the material bed and are conveyed up to the heavy discharge by the deck’s vibration. “Light” particles, lifted by the airstream, float off the lower end of the deck. As the material flows toward the broad discharge side of the deck, the material spreads and a sensitive gradation results.

Intermediate particles or boundary mixtures discharge between the two extremes. These boundary mixtures, referred to as “middlings”, may be recycled for further separation, either by hand or by an optional pneumatic conveyor.

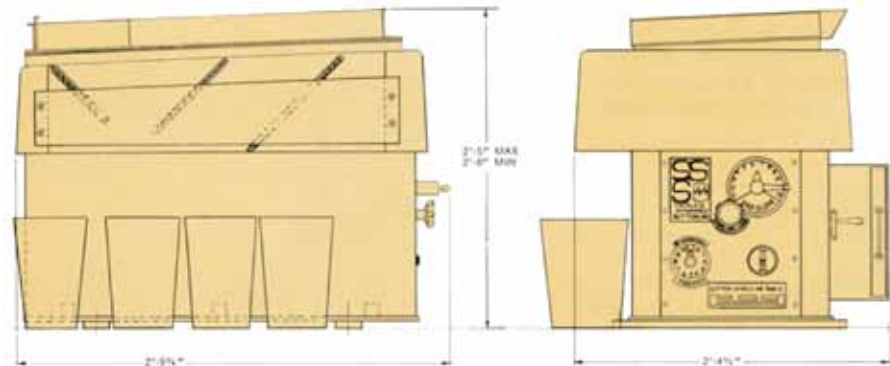
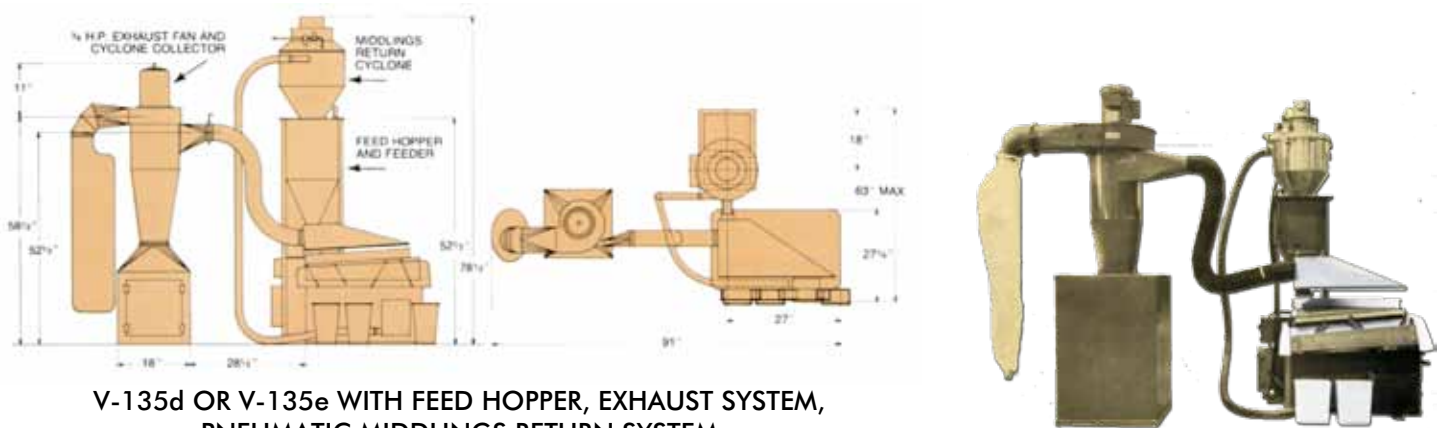

OPTIONAL ACCESSORIES

A one cubic foot feed hopper with variable-rate feeder; a pneumatic middlings return system; and a canopy dust hood with flexhast coupling hose, dust fan with 3/4 HP motor, and cyclone collector with exhaust filter bag.



Triple/S Dynamics, Inc.
1031 S. Haskell Avenue ■ Dallas, TX 75223
Ph. 214-828-8600 ■ 800-527-2116 ■ www.sssdynamics.com